

DESIGN AND TESTING OF A 50N HYDROGEN PEROXIDE MONOPROPELLANT ROCKET THRUSTER

Norazila Othman, Subramaniam Krishnan, Wan Khairuddin bin Wan Ali* and
Mohammad Nazri Mohd Jaafar¹.

Faculty of Mechanical Engineering,
Universiti Teknologi Malaysia,
81310 Skudai, Johor Bahru.

ABSTRACT

Among research and development activities concerning the monopropellant thrusters are on the safe handling of the propellant and the environmental issue rises from the toxicity of the combustion products. The development of the “green” propellant was a reaction toward controlling the release of toxic combustion products. Using the hydrogen peroxide as the monopropellant and silver screen as the catalyst to enhance the performance of thruster, oxygen and superheated steams are the only combustion products produced. The non-toxic hydrogen peroxide on its own is very stable at room temperature and with the non-toxic combustion products qualify it as green propellant. The results show that the output from decomposition process produces no other toxic materials. Thrusters of 50N thrust or below can be used in satellite application and the problem is to develop this thruster using Hydrogen Peroxide monopropellant. This paper presents the chemical equation of the silver-catalyst chemical decomposition of the hydrogen peroxide and the design of 50N hydrogen peroxide monopropellant rocket thruster. The provision for varying injector orifice diameter was also incorporated in the design. The test results of rocket thruster using hydrogen peroxide of concentration above 90% are presented. The results indicate that for the successful operation of rocket thruster, the catalyst pack should be heated above 100°C and high purity hydrogen peroxide should be used.

Keywords: *Hydrogen peroxide, monopropellant, rocket thruster, catalyst pack.*

1.0 INTRODUCTION

Propellant systems for liquid rockets generally falls into two categories (1) monopropellant and (2) bipropellant [1]. Monopropellant rocket uses single fluid system as propellant and the most commonly used monopropellant is hydrazine (N₂H₄) which is highly toxic and dangerously unstable unless handled in solution [1]. In bipropellant rockets, two fluids system is used to form the propellant and they are categorised into fuel and oxidizer such as the most commonly use combination of monomethylhydrazine (MMH) and nitrogen tetroxide (N₂O₄) which are highly toxic and unstable [1-2]. The above mentioned propellant combinations require special propellant handling and prelaunch preparation. Due to that, hydrogen peroxide (H₂O₂) have become considerably more attractive liquid as possible substitutes for hydrazines and nitrogen tetroxide [3-7]. According to the Wernimont E. J. [8], the rocket grade H₂O₂ (concentration above 85%) is a non-toxic chemical that has a natural familiarity to human chemistry thus it is the best general solution for space, air, land and sea applications.

Among other concerns when choosing H₂O₂ as a monopropellant are also the

*Corresponding author : wankhai@fkm.utm.my

significant cost saving associated with the drastic simplification of health and safety precautions necessary during the production and the storage and handling of the propellants [2]. These advantages have a special relevance to low or medium thrust thruster, where the above cost does not scale down proportionally with the thruster size. The H₂O₂ monopropellant is considered safe because of the mechanism for the propulsion is derived from the silver screens which act as a catalyst for chemical decomposition of the H₂O₂. The governing reaction equation for the decomposition process involving H₂O₂ is given in equation (1):

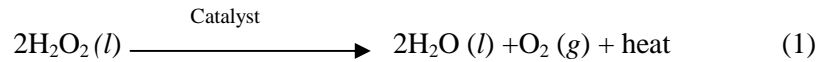

Equation (1) shows that only the superheated steam and oxygen are released from decomposition process. It means that no other toxic gas is released to the air. Based on this fact, the rocket grade H₂O₂ was prepared with the concentration up to 90%.

The objective of this research is to achieve 50N thruster which can be used for satellite propulsion application. This small thrust is needed for controlling the position of the satellite and to correct the orbit position [9]. The scope of this paper is to present a detailed design procedure to achieve 50N thrusters using H₂O₂ monopropellant. In addition, the test facility is shown and some preliminary experimental results of thruster firing are presented for discussion. In current research, it was decided to design and build a laboratory scale 50N H₂O₂ monopropellant thruster facility in the Department of Aeronautical Engineering, Universiti Teknologi Malaysia.

2.0 THRUSTER DESIGN

The design process started with design specifications as follows; 1) The thruster propellant is H₂O₂ with concentration of 90%, 2) The thrusting time is to be in excess of 10 seconds, 3) The nozzle entry stagnation pressure is 2MPa and, 4) The nozzle pressure ratio is 15. To assist the design process, public domain software developed by United State space agency called NASA CEC71 program [10] was utilised and the thruster theoretical performance was calculated with results shown in Table 1.

The design of catalyst screen requires two important parameters that are; 1) the average mass flux through the screen (the so called screen loading) and 2) the average residence time in the screen. Pure silver screen is selected due to its commercial availability and its purpose is to promote H₂O₂ self-decomposing at high temperatures and also to enhance the performance of thruster [11]. The thruster performance could also be enhanced using other catalysts such as Rhodium, Palladium, Platinum and gold but they are expensive and hard to get compared to the silver [12]. The purity of 100% silver screen must be chosen as to avoid any impurity leading to catalytic poisoning which can disturb the thrusters' performance [11]. After passing through the catalyst chamber, high pressure gas mixture is released through the thruster nozzle and applying the Newton laws of motion, the flow velocity is taken as the reaction force or thrust [1].

Typical adopted value for average mass-flux through silver screen varies from 117- to 280-kg/m²-s [12-14]. The average residence time in the catalyst bed varied from 0.7ms to 1.5ms [13-15]. In general, the quality factor for c^* (or c^* efficiency) η_{c^*} is taken as 0.95 for bipropellant liquid thrusters and solid propellant motors. Since the thruster under consideration is a monopropellant and the quality of decomposition is very much dependent on the catalyst, a conservative value of 0.90 is assumed for the quality factor [16]. Therefore, using the calculated theoretical-values given in Table 1,

$$c_{expt}^* = \eta_{c^*} c_{theo}^* = 846 \text{ m/s} \quad (2)$$

$$\begin{aligned} (C_{F \text{ sealevel}})_{theo} &= C_F^0 + \frac{A_e}{A_t} \left(\frac{P_e}{P_{0n}} - \frac{P_a}{P_{0n}} \right) \\ (C_{F \text{ sealevel}})_{theo} &= 1.3808 \end{aligned} \quad (3)$$

Table 1 : Theoretical rocket performance characteristics of the hydrogen peroxide thruster assuming frozen flow and 90 % hydrogen peroxide concentration [16]

Symbols	Chamber	Throat	Exit
P_{0n} / P_e	1	1.8188	15
P (MPa)	2.0	1.013	1.333
T (K)	1029.5	906.39	559.65
\bar{m} (kg/kg-mol)	22.105	22.105	22.105
γ	1.2648	1.2764	1.3158
A_e / A_t	--	1.0	2.6713
c^* (m/s)	--	940	940
C_F^0	--	0.702	1.338

Assuming a quality factor for the thrust coefficient $\eta_{C_F} = 0.95$,

$$(C_{F \text{ sealevel}})_{expt} = \eta_{C_F} (C_{F \text{ sealevel}})_{theo} = 1.3117 \quad (4)$$

$$(I_{sp \text{ sealevel}})_{expt} = c_{expt}^* (C_{F \text{ sealevel}})_{expt} = 1109.7 \frac{N \cdot s}{kg} \quad (5)$$

Propellant mass flow rate,

$$\dot{m}_p = \frac{F}{(I_{sp \text{ sealevel}})_{expt}} = 0.04506 \frac{kg}{s} \quad (6)$$

An average mass-flux Φ of 200 kg/m²-s is assumed for the thruster [12-14]. Therefore, the cross sectional area for catalyst bed is:

$$A_{CP} = \frac{\dot{m}_p}{\Phi} = 0.2255 \times 10^{-3} m^2 \quad (7)$$

Then, the diameter of the catalyst pack = 0.0169 m (say 17 mm). Combustion chamber temperature,

$$T_0 = T_{ad} \eta_c^{2*} = 1029.5 \times 0.9^2 = 834K \quad (8)$$

For the assumed residence time Δt of 1.5 ms, the catalyst bed length,

$$L_{CP} = \frac{R_u \dot{m}_p T_0 \Delta t}{\bar{m} (\pi D_{CP}^2 / 4) p_{0n}} = 0.047m \quad (9)$$

In order to avoid the tunnelling effect of H₂O₂ through the catalyst pack, two perforated distribution stainless steel plates are introduced at the beginning, and the end of the catalyst pack. Each of the distribution plate has 2mm thickness. Therefore the total length of the catalyst pack is rounded at 50 mm.

2.1 Injector Orifice

In the combustion chamber of monopropellant, the high pressure condition is needed to accelerate the hot gas mixture. Therefore, a feed system is needed to pressurize and transport the propellant from the propellant tank to the thrust chamber [17]. Due to this reason, about 0.6MPa or 10% of the chamber pressure is allowed as the pressure drop across the propellant injector Δp_i [16]. In this research a pressure drop of 0.7MPa is liberally allowed across the propellant injector to make sure no atomization, no feed-system linked instabilities and no excess energy used were to occur during firing [18].

For the mass flow rate of 0.04506 kg/s, assuming the coefficient of discharge for the injector orifice is 0.8 and noting that the propellant density, ρ_p of H₂O₂ of 90% concentration is 1380 m³/kg, the orifice diameter is calculated as [16].

$$D_i = \left(\frac{4\dot{m}_p}{c_d \pi \sqrt{2\Delta p_i \rho_p}} \right)^{0.5} = 0.00127m \quad (10)$$

Nominal rounded diameter for the injector orifice is kept at 1.3mm. As the variation of propellant injection characteristics are to be considered for the study of thruster performance, different orifice diameters from 0.6mm to 2mm are selected.

2.2 Nozzle Dimensions

The mass flow-rate through the choked nozzle is given by,

$$\dot{m}_p = \frac{p_{0n} A_t}{c_{expt}^*} \quad (11)$$

Therefore, the throat diameter is calculated as 0.00493m. Rounding this diameter to 4.5 mm and for the area ratio $A_e/A_t = 2.6713$ (Table 1) the nozzle exit diameter is calculated as 7.4 mm.

In this design, the throat diameter 3.5mm is also selected for parametric study. Then the corresponding nozzle exit diameter with the nozzle area ratio of 2.6713 is 5.7mm. A half-cone angle of 13° is selected for the nozzle exit cone.

2.3 Propellant Tank Pressure

For the mass flux of 200 kg/m²-s, the pressure drop across the catalyst pack Δp_{cp} is expected to be about 0.85MPa [12]. Therefore the pressure upstream of catalyst pack is 2.85MPa. With the pressure drop of 0.7MPa across the injector orifice and 0.2MPa across the solenoid valve, the propellant tank pressure is 3.75MPa. A minimum pressure drop of 1.0MPa is to exist at the pressure regulator. Therefore the minimum pressure upstream of the pressure regulator is 4.75MPa [16].

2.4 Propellant Tank Volume

In designing the propellant tank volume, thrusting time is to be about 10s. As the test facility realized for testing H₂O₂ thrusters has propellant tank volume of 1 litre, depending on the thrusting time required for the 50N thruster, different volumes of concentrated H₂O₂ can be filled into the propellant tank, the propellant tank volume can be calculated as,

$$V_{pt} = \frac{1.1 \times \dot{m}_p \Delta t_F}{\rho_p} = 359.17 \times 10^{-6} m^3 \quad (12)$$

A rounded tank volume of 500 ml is chosen.

$$\dot{V}_p = \frac{\dot{m}_p}{\rho_p} = 32.652 \times 10^{-6} \frac{m^3}{s} \quad (13)$$

Therefore the maximum possible thrusting time,

$$t_{max} = \frac{V_{pt} \times 0.9}{\dot{V}_p} = 13.8s \quad (14)$$

As it is not being envisaged to fix any anti-vortex unit at the outlet within the propellant tank, arbitrarily a time of 12s is fixed as the maximum rated thrusting time. The assembly drawing of the thruster that has been fabricated is shown in Figure 1. The specifications of the thruster are given in Table 2.

Figure 2 shows the quarter section view of the designed thruster and Figure 3 shows the image of the fabricated thruster. As the catalyst pack length is a parameter to be varied, sleeves of different lengths are introduced before the nozzle with dimension 11 and 22mm.

Table 2 : Specifications of the monopropellant rocket thrusters

Engine thrust	50 N
Estimated specific impulse	1110N-s/kg
Regulated H ₂ O ₂ tank pressure	3.75 MPa
Injector pressure drop	0.70 MPa
Injector orifice diameter	1.3 mm
Nozzle entry stagnation pressure	2.0 MPa
Propellant flow rate	0.04506 kg/s
Propellant density	1380 kg/m ³
Catalyst bed length	50 mm
Approximate thrusting time	10 s
Nozzle throat diameter	4.5 mm/3.5mm
Nozzle exit diameter	7.4 mm /5.7mm

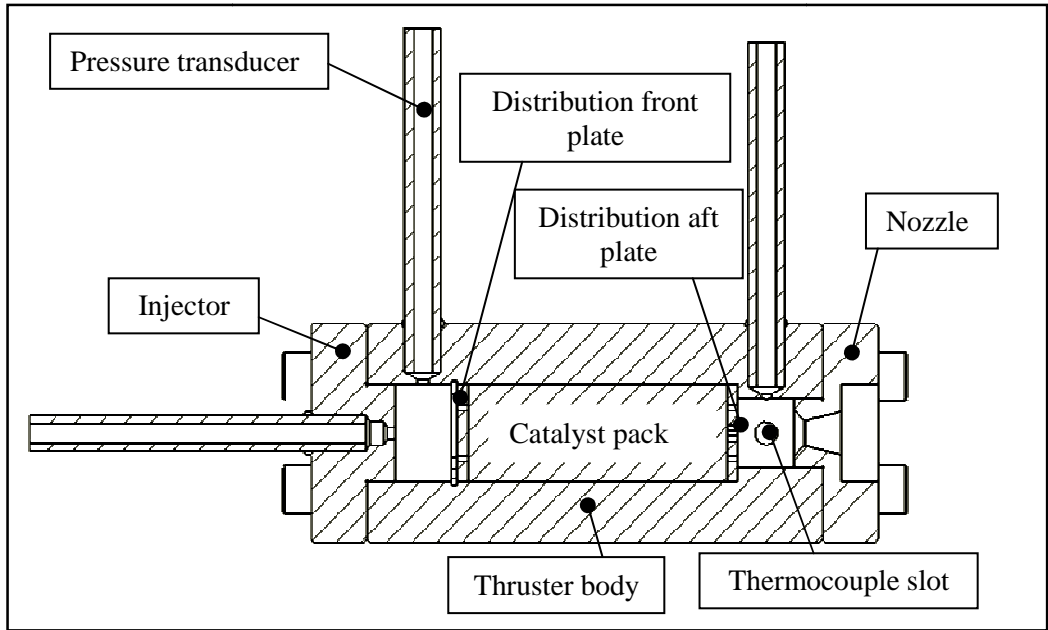

Figure 1: 50N hydrogen peroxide rocket thruster.

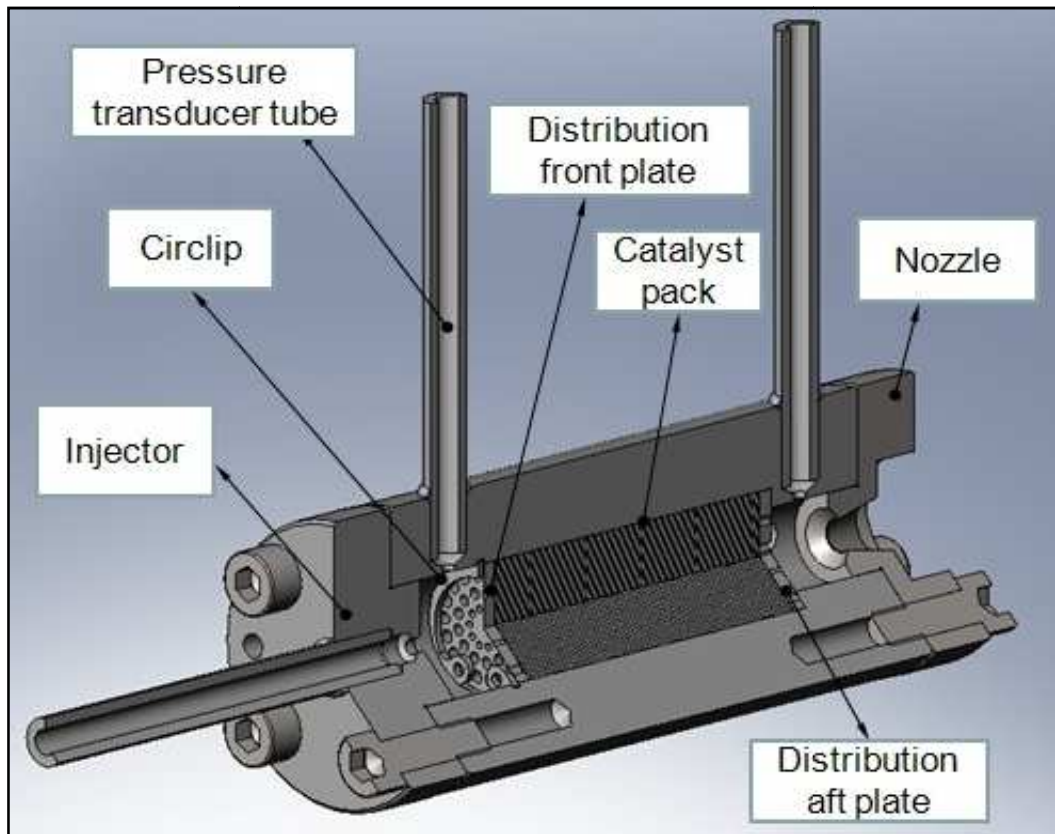

Figure 2 : Quarter section view of 50 N hydrogen peroxide thruster.



Figure 3 : The photography picture of fabricated thrusters.

3.0 EXPERIMENTAL SET-UP AND TESTING

3.1 Test Facility

Figure 4 show the image and assembly details of the realized experimental setup. Sufficient safety features have been incorporated by introducing burst diaphragm and relief valve in the test facility. All the control valves are remotely operated by pressurized nitrogen. Pressure transducers are fitted at five stations: pressurization tank, propellant tank, upstream of the injector, chamber pressure upstream of the catalyst pack, and downstream of the catalyst pack.

Propellant is filled into the tank through quick connectors. Pressure regulator is set to the required propellant tank pressure. Recording and display of the pressure transducer-readings are initiated. Nitrogen supply is opened and it enters the gas pressurization tank of 1000cc volume after passing through 40 and 7micron filters (Figure 6). Once the propellant tank pressure is stabilized, shut-off valve is opened to initiate the engine operation. The thruster is fired until the propellant is consumed (~12s for 350ml of propellant). Once the propellant is consumed nitrogen-purging automatically follows to cool the thruster.

In order to gain experience in the operation of the facility and also to prove the system, the facility has been tested extensively under simulated condition using water as well as nitrogen. While using nitrogen, the injector orifice and nozzle throat diameters were altered to simulate the thruster operation.

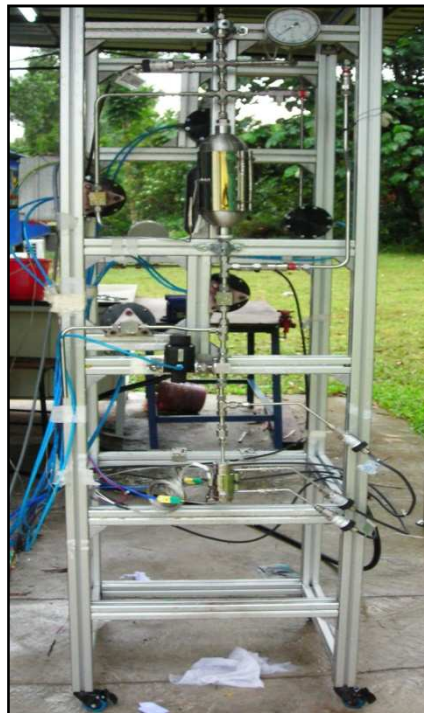

Figure 4 : Hydrogen peroxide rocket thruster facility.

3.2 Coefficient of Discharge

Although we have assumed a discharge coefficient of 0.8, we have to experimentally evaluate the discharge coefficient for the designed injector orifices. Coefficient of discharge is given by Equation 15. Water is used as a surrogate fluid.

$$c_d = \frac{V}{(\pi/4)d^2 \Delta t \sqrt{2\Delta p/\rho}} \quad (15)$$

The values of discharge coefficient obtained for 0.602, 1.045, 1.367 and 2.011 mm injectors are given in Figure 5. The experimental values are different from the value of discharge coefficient assumed for the design. This variation will have to be taken into account during the performance estimation of the thruster.

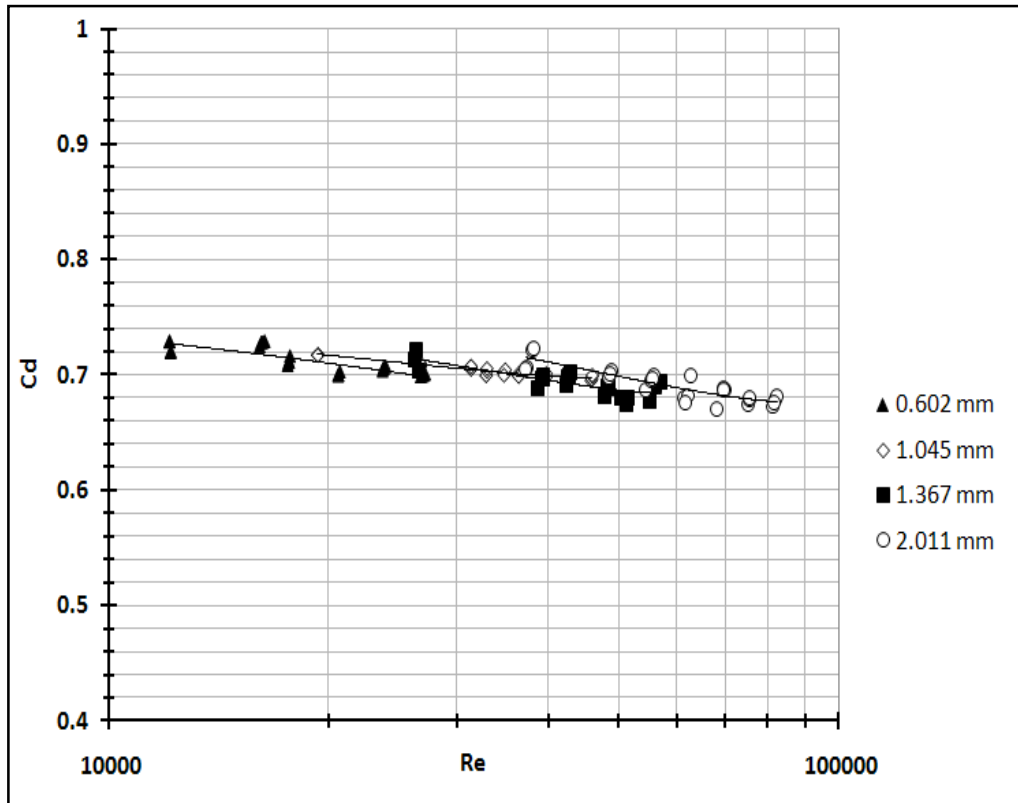

Figure 5 : Discharge coefficient for four different diameter injectors.

3.3 Hot Test

40 mesh pure silver screens were used for the catalyst pack. The silver screens were initially pickled with 10 % nitric acid and subsequently activated with 4% solution of samarium nitrate. The total catalyst-bed length of 50mm was stacked with 40 mesh silver screens interposed with two perforated separator discs of stainless steel (each of 2mm thick). The total catalyst bed was compacted at 9.29MPa [16].

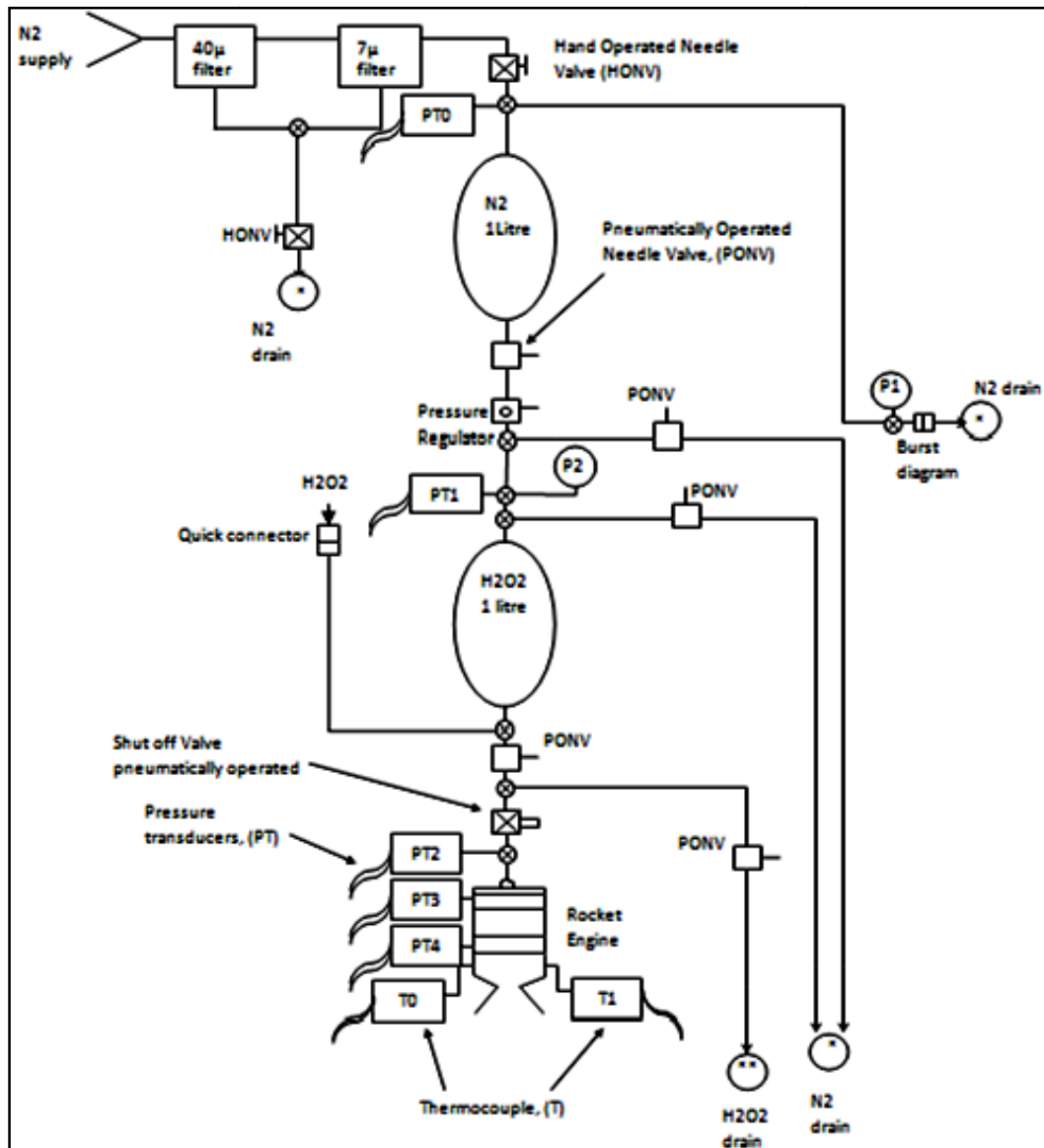

Figure 6 : Line diagram of hydrogen peroxide rocket thruster facility.

4.0 RESULTS AND DISCUSSIONS

The initial firing test was using 29bar injection pressure, catalyst pack temperature is 150 degree Celsius, and thruster temperature is 50 degree Celsius. The configurations of the thruster are: injector orifice with 1.367mm diameter, nozzle throat with 4.5mm diameter and 9.29MPa for the compaction pressure of catalyst pack. A test result is shown in Figure 7. The initial attempt to fire the thruster was successful with no white smoke released from the nozzle [7]. The graph also shows the line is stable (not fluctuate), so the firing is completely decompose. From the observation, the released gases are only superheated steam and oxygen. Odourless combustion products detected thus showing that the complete decomposition of the monopropellant caused by the catalyst. Meanwhile in the unsuccessful firing, white smoke and acidic smell was detected in the combustion products [7]. This is due to the incomplete decomposition of monopropellant caused by

contamination of the catalyst during the preparation of the catalyst pack or the concentration of hydrogen peroxide is not greater than 88% or stabilizers present inside the H_2O_2 [18]. A low concentration of H_2O_2 and with the present of stabilizers inside the H_2O_2 will give the low performance of the thruster [12-13].

However, from the test, the pressure drop through the injector Δp_i and catalyst pack ΔP_{cp} is less than 0.7MPa. The pressure drop through the catalyst pack is an important design parameter and this is known to be a function of mass flux, Φ [18]. As mentioned earlier in section 2.1, these pressure drops are important to determine whether atomization had occurred, the firing is stable and the amount of energy usage for the system. If the pressure drops more than 0.7MPa, it shows that the firing testing uses extra energy even though the performance is still same. From the graph, it shows that atomization did not occur and resulting in stable firing because the line of the graph is not fluctuating although the pressure drops less than 0.7MPa. The effect of this condition is that the thruster uses less energy thus less thrust will be produced. Both injector and catalyst pack pressure drops also can be interpreted to avoid any disturbance inside the thruster during the testing. The test show that the value of 0.7MPa pressure drops is the best pressure drop suitable to achieve 50N thrust with the entire requirement as mention earlier.

For the next development activity, the injector diameter was decreased to 1.045mm, nozzle throat diameter and compaction pressures of the catalyst pack are remain the same. The catalyst pack and thruster temperature was heated and maintained at 150°C and 50°C respectively. The result was shown in Figure 8. From the graph, it shows the complete decomposition of the monopropellant. Only superheated steam and oxygen are released. The hot test with these modifications was successful with pressure drop through the injector Δp_i and catalyst pack ΔP_{cp} are around 0.7MPa. The reason more pressure drops obtained when using the small injector orifice diameter is the increasing of the mass flow rate through the system which cause the system require more energy to accelerate the hot gases out of the nozzle. Thus, more energy with the suitable value 0.7MPa is used, no atomization and stable condition occurs during experiment. From this firing, the thrust produced is almost 50N. The firing experiments demonstrate acceptable pressure drops across the injector Δp_i and catalyst pack ΔP_{cp} [18].

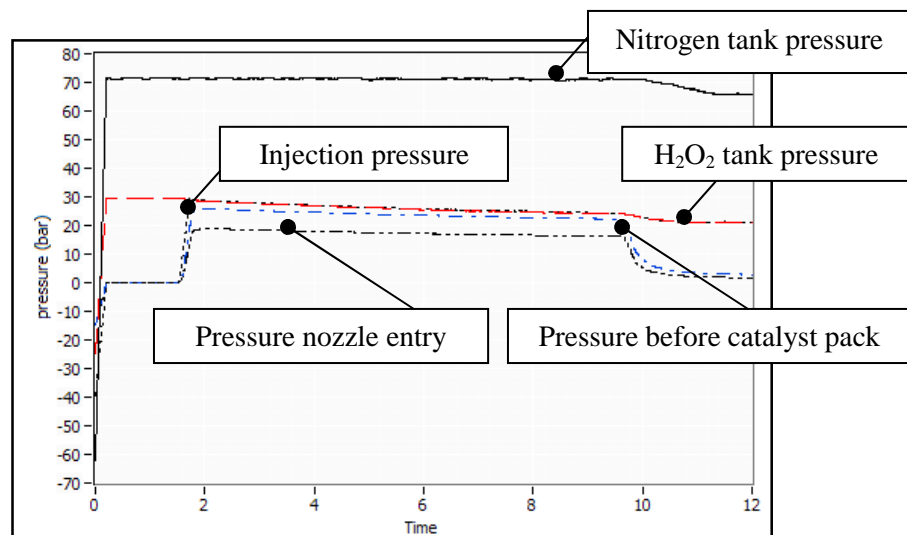

Figure 7 : Typical result by using 1.367mm diameter injector which is not achieve 0.7MPa pressure drop.

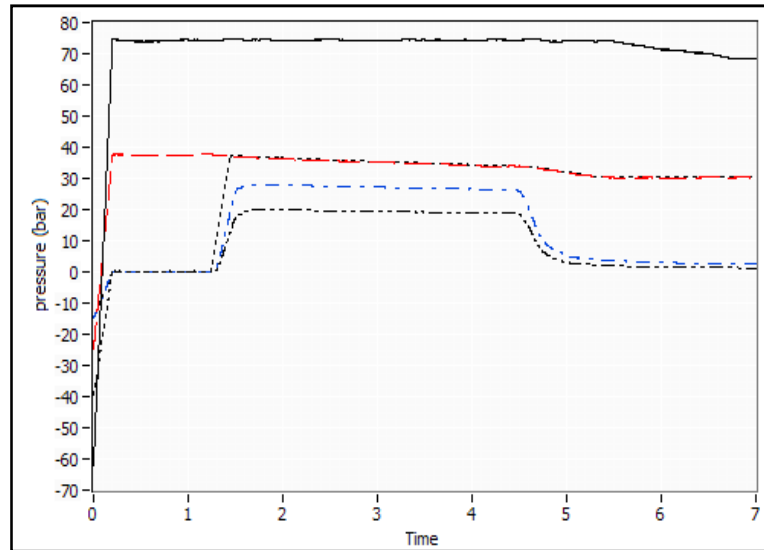

Figure 8 : Successful result by using 1.045mm diameter injector which is achieve 0.7MPa pressure drop.

5.0 CONCLUSIONS

The results from the firing test show that the complete combustion of the monopropellant thruster is achieved. The superheated steam and oxygen which released from the nozzle are the proved that there is no other toxic gas released during firing. The same result was also reported by Runckel et al. [14] which tell us that, the complete combustion can be determine from the parallel lines on the graph. From this firing, the pressure drops through the injector Δp_i and catalyst pack ΔP_{cp} could be known and interpret the condition of the thruster in the combustion chamber. A detailed design of a laboratory scale facility of the H_2O_2 monopropellant thruster of 50N thrust has been presented. Following the design, the thruster has been fabricated. Initial hot tests shows that pressure drops less than 0.7MPa produced thrust less than 50N. In further firing test, acceptable pressure drops was achieved by reducing the injector orifice diameter. By choosing the suitable injector orifice diameter while keeping others parameter fix, it achieved 50N thrust.

ACKNOWLEDGEMENTS

The research reported here forms a part of the work carried under the project entitled, "Development of a 100N Monopropellant Hydrogen Peroxide Rocket Engine Facility and Catalyst Design Studies" funded by the Ministry of Science, Technology, and Innovation (MOSTI) of Malaysian Government.

REFERENCES

1. Joseph A. A., 2003. Space Technology, United Satates of America.
2. Ventura, P. M. Wernimont, E. J., Heister, S. and Yuan, S., 2007. Rocket Grade Hydrogen Peroxide (RGHP) for Use in Propulsion and Power Devices - Historical

- Discussion of Hazards, *43rd AIAA/ASME/SAE/ASEE Joint Propulsion Conference and Exhibit*, Cincinnati, OH, AIAA 2007- 5458.
3. Rusek, J. J., 2004. Hydrogen Peroxide for Propulsion and Power Applications, *Proceedings of 2nd International Conference on Green Propellants for Space Propulsion*, Cagliari, Italy.
 4. Cervone, A. Romeo, L. Torre, L. Calderazzo, F. Musker, A. J. Roberts, G. T. and Saccoccia, G., 2007. Development of Green Hydrogen Peroxide Monopropellant Rocket Engines and Testing of Advanced Catalytic Beds, *43rd AIAA/ASME/SAE/ASEE Joint Propulsion Conference and Exhibit*, Cincinnati, OH, AIAA-2007-5465.
 5. Fisher, S. C., Dec. 2002. Liquid Propulsion, *Aerospace America*, vol. 40, pp. 64-65.
 6. Roy, L. P. Kappenstein, C. Guerin, M. Eloirdi, R. and Pillet, N., Nov-Dec. 2002. Hydrogen Peroxide Decomposition on Various Supported Catalysts Effect of Stabilizers, *Journal of Propulsion and Power*, vol. 18, pp.1235-1241.
 7. Sorge, A. R. Turco, M. Pilme, G. Bagnasco, G., 2004. Decomposition of Hydrogen Peroxide on MnO₂/TiO₂ Catalyst, *Journal of Propulsion and Power*, vol. 20, No 6, pp. 1069 -1075.
 8. Wernimont, E. J., 2006, Monopropellant Hydrogen Peroxide Rocket Systems: Optimum for Small Scale, *42nd AIAA/ASME/SAE/ASEE Joint Propulsion Conference & Exhibit*, Paper AIAA-2006-5235, Sacramento, CA.
 9. Larangot, B., Conedera, V., Dubreuil, P., Conto, T. D., Rossi, C., 2004, Solid Propellant Microthruster: An Alternative Propulsion Device for Nanosatellite, Toulouse Cedex 4, France.
 10. Gordon, S. and McBride, B.J., 1971. Computer Program For Calculation of Complex Chemical Equilibrium Compositions, Rocket Performance, Incident and Reflected Shocks, and Chapman-Jouguet Detonations, NASA SP-273.
 11. Eloirdi, R., Rossignol, S., Kappenstein, C., and Duprez, D., (2000), Catalytic Decomposition of Different Monopropellants, *Proceedings of 3rd International Conference on Spacecraft Propulsion*. Cannes. 10-13 October 2000.
 12. Wernimont, E. J. and Mullens, P., 2000. Capabilities of Hydrogen Peroxide Catalyst Beds, *AIAA Paper* 2000-3555.
 13. Wills, C. M., 1960. The Effects of Catalyst Bed Arrangement on Thrust Buildup and Decay Time For a 90 % Hydrogen Peroxide Control Rocket, NASA TND-516.
 14. Runckel, J. F. Wills, C. M. and Salters, Jr. L. B., 1963. Investigation of Catalyst Beds for 98% Concentration Hydrogen Peroxide, NASA TND-1808.
 15. Love, J. E. and Stillwell, W. H., 1959. The Hydrogen Peroxide Rocket Reaction Control System, NASA TND-185.
 16. Hee, A. S. Krishnan, S. Won, L. C., 2010. Design and Development of a Hydrogen Peroxide Rocket Engine Facility, *Jurnal Mekanikal*, No. 30, 24 – 36.
 17. Liquid Rocket System, Delft University of Technology. URL: <http://lr.tudelft.nl/index.php?id=26229&L=1> (10 August 2011).
 18. Norazila O., 2011. Design and Development of a 50N Hydrogen Peroxide Monopropellant Thruster, Master thesis, *Universiti Teknologi Malaysia*.